



3/4" REUSABLE CONCRETE ANCHOR

INSTRUCTION MANUAL

THE INSTRUCTIONS APPLIES TO

THE FOLLOWING MODELS: RCA5K

REUSABLE CONCRETE ANCHOR INSTRUCTION



This product is part of a personal fall arrest, restraint, work positioning, personnel riding, or rescue system. The user must follow the manufacturer's instructions for each component of the system. These instructions must be provided to the user of this equipment. Serious injury during fall arrest can be prevented by using compliant fall protection and emergency rescue systems. Users must understand the manufacturer's instructions and be trained in the proper use of this product per OSHA 29 CFR 1910.66 and 1926.503 or applicable local standards. Manufacturer's instructions must be followed for proper installation, use, care, and maintenance of this product. These instructions must always be available for reference. Alterations or misuse of this product or failure to follow instructions may result in serious injury or death.

IMPORTANT: This manual is intended to meet the manufacturer's instructions as required by the American National Standard Institute Z359.18. This manual must always be available to the user and is only permitted to be removed by the user of this equipment. For proper use refer to supervisor, user instructions, or contact the manufacturer. Do not alter or intentionally misuse this equipment.

1. Warnings Regarding The Removable Concrete Anchor

- » To safely use this equipment, the user must have a sound mind and body. The user should also consult a physician to ensure they are clear of any medical conditions that may influence their ability to safely use this equipment in normal and emergency situations.
- » Users must be trained in accordance with OSHA 29 CFR 1910.66 requirements regarding the safe use of the system and its components before using a personal fall arrest system.
- » Use only with ANSI/OSHA compliant personal fall arrest or restraint systems. The anchorage must have the strength capable of supporting a static load, applied in the directions permitted by the system, of at least 5,000 lbs. in the absence of certification.
- » Users must be equipped with the means to limit the maximum dynamic forces exerted on them during fall arrest to a maximum of 1,800 lbs.

- » Before use, a competent engineer or other qualified person must verify that this anchorage connector is compatible with the structural and operational characteristics of both the installation location and the system that it will be connected to.
- » Before use, the anchorage connector must be inspected for a variety of factors, including wear, damage, and other deterioration. Components that do not pass this inspection must be immediately removed from service in accordance with the requirements of OSHA 29 CFR 1910.66 and 1926.502.
- » Immediately after falling, the anchorage connector must be removed from service and destroyed.
- » Before use, the complete fall protection system (including all components, calculating fall clearance, and swing fall) should be planned. Ensure the anchorage connector is positioned to minimize the potential for falls and the potential distance during use.
- » Users must have a rescue plan, and the means on hand to implement it, that either: ensures the prompt rescue of users in the event of a fall or assures that users are able to rescue themselves.

2. Warnings Regarding Working at Height

- » Before use, consult your doctor to ensure that your physical condition allows you to safely withstand the impact of all forces involved with working at height.
- » Do not use any fall protection equipment that has failed inspection.
- » Ensure all connections are compatible, and that all subsystem combinations do not interfere with the function of this fall arrest system.
- » Ensure that a written rescue plan, and the means to implement it, are always available when using this equipment.
- » Immediately seek medical attention for the affected party if a fall event occurs.
- » When inspecting, installing, or using the device / system, always ensure that you wear appropriate Personal Protective Equipment.
- » Never expose workers to fall hazards during training.

IMPORTANT: Immediately remove equipment from service if it has been subject to a fall arrest forces OR has failed inspection (see Section 11 for inspection procedures).

3. Key Components and Materials

Refer to Figure 1 for identification of key components of RCA5K Removable Concrete Anchor.

1. Anchor Body – Stainless Steel
2. Cable Sleeve – PE
3. End Termination – Stainless Steel
4. Wedges – Stainless Steel
5. Spring – Stainless Steel
6. Collar – Stainless Steel
7. Connection Loop – Steel
8. Swage – Aluminum
9. Connection Loop Sleeve –TPU
10. Washer – Stainless Steel
11. Warning Tag – Nylon Fabric

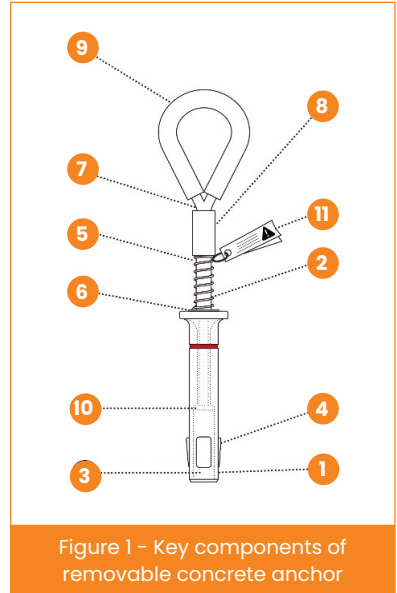

4. Limitations

Do not use the RCA5K Removable Concrete Anchor outside its limitations, or for any purpose other than that for which it is intended.

Weight Capacity

As per ANSI, the anchorage connector is designed for single users, with a capacity up to 310 lbs., including clothing, tools, etc.

Permissible Directions of Loading

The anchorage connector may not be subject to forces outside of the allowable range shown in Figure 2.

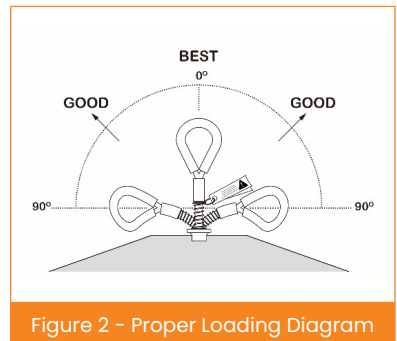

Temperature

The anchorage connector is designed for use in temperatures ranging from -30°F to +130°F (-34°C to +54°C).

Compatibility

The RCA5K Removable Concrete Anchor should only be coupled to compatible connectors. According to OSHA 29 CFR 1926.50 requirements, snap hooks are prohibited from being engaged to objects unless two requirements are met: it must be a locking type of snap hook, and it must be "designed for" making such a connection. When a snap hook is "designed for" a connection, it means the manufacturer specifically designed said snap hook to connect to the equipment listed.

According to ANSI Z359.0-2007, rollout describes a process by which a snap hook or carabiner unintentionally disengages from another connector or the objects to which it is coupled. The following connections must be avoided, since they can result in a rollout if a non-locking snap hook is used:

- » Direct connection of a snap hook to horizontal lifeline.
- » Two (or more) snap hooks connected to one D-ring.
- » Two snap hooks connected to each other.
- » A snap hook connected back to its integral lanyard.
- » A snap hook connected to a webbing loop or webbing lanyard.
- » Improper dimensions of the D-ring, rebar, or other connection point in relation to the snap hook dimensions that would allow the snap hook keeper to be depressed by a turning motion of the snap hook.

Making Connections

This equipment should only be used with self-locking connectors (i.e.: snap hooks, rebar hooks, and carabiners) that are suitable for each application. All connectors should be compatible in size, shape, and strength; do not use equipment that is not compatible. Before using it, ensure all connectors are fully closed and locked. Connectors are designed for use only as specified in this manual.

Personal Fall Arrest Systems (PFAS)

Typical components of a PFAS include a properly fitted and adjusted Full Body Harness (FBH); an energy absorbing connecting device, such as an Energy Absorbing Lanyard (EAL) or SRD, or a fall arrester connecting subsystem that is attached to the dorsal D-ring of an FBH; and an anchorage. Ensure all PFAS used with this equipment meet OSHA requirements. As required by OSHA, the PFAS must be able to arrest the user's fall with a maximum arresting force (MAF) of 1,800 lbs. and limit free fall to 6 ft.

PFAS Anchorage Strength

Anchorage selected for use in a PFAS must be able to sustain a static load applied in the direction permitted by the PFAS of at least:

- A. Two times the maximum arrest force permitted (when certification exists), or
- B. 5,000 lbs. in the absence of certification.

When selecting an anchorage location, users must consider a variety of factors including structural strength, obstructions in the fall path, and swing fall hazards. In certain situations, a qualified person can determine that a given structure is able to withstand the applied MAF of the PFAS with a safety factor of at least two.

Free Fall

As specified by ANSI Z329.1, the free fall of any PFAS system used with this equipment must be limited to 6 feet. For more information, refer to the PFAS manufacturer's instructions. Restraint systems, personnel riding systems, and rescue systems used with this equipment must not allow any vertical free fall. Work positioning systems must limit free fall to 2 feet or less.

Fall Clearance

The user should always assess their working environment to ensure there is sufficient clearance below them to arrest a fall before they strike the ground or other obstruction. The clearance required is dependent on the following factors:

- » Deceleration distance
- » Free fall distance
- » Worker height
- » Movement of harness attachment element
- » Elevation of d-ring anchorage connector
- » Connecting Subsystem Length

For more information, refer to the PFAS system manufacturer's instructions.

Swing Falls

As shown in Figure 2, swing falls happen when the anchorage point is not directly above the point at which a fall occurs. The resultant force of striking an object in a swing fall may cause serious injury or death. If injury could occur, swing falls are not permitted. To minimize swing falls, the user should work as close to the anchorage point as possible. If the PFAS system involves an SRD or other variable length connecting subsystem, swing falls will significantly increase the clearance required.

Use Limitations

- » Do not expose the anchorage connector to chemicals or harsh solutions that may have a harmful effect.



Figure 3 - Swing Fall

- » Do not alter or modify this anchorage connector.
- » Contact between any component of a fall protection, work positioning, rope access, or rescue system and nearby moving machinery, electrical hazards, sharp edges, or abrasive surfaces may cause equipment failure, personal injury, or death.
- » Users must be trained by a "competent person" as defined by OSHA 29 CFR 1926.32(f) before installing / using this equipment.
- » Do not remove the labeling from this product. (see Appendix A for images of labels)
- » Before installation, all placements must be approved by a competent engineer or other qualified person. Additional considerations may apply depending on anchorage type and fastening option utilized for installation.
- » This anchorage connector should not be used as part of a horizontal lifeline system that is not compatible with / has not been designed for 5,000-lbs. anchorage connectors.
- » This anchorage connector is only for personal fall protection, not for lifting equipment.

5. Training

Installation of this equipment must be performed by persons with training in its correct application and use. The user bears full responsibility for understanding the contents of these instructions and assuring they are trained in the correct care and use of this equipment, such as the operating characteristics, application limits, and consequences of improper use. During training, the user must not be subjected to a fall hazard.

6. Specifications

Performance

- » Minimum Breaking Strength: 5,000-lbs.
- » Maximum Capacity: One Worker with maximum weight of 310-lbf, including clothing, tools, etc., when used as a single point anchorage connector for person fall arrest or restraint system.

Regulatory Compliance

- » ANSI Z359.18 Type A

7. Applications



Swing fall may occur when the worker is not directly under anchor point.

Purpose

The RCA5K Removable Concrete Anchor should be installed into a pre-drilled hole made within a minimum of 3,000 PSI fully cured concrete. Additional installation specifications regarding concrete thickness and edge distance are also described within the manual – for more information, refer to Section 8.5. The structure to which the RCA5K Removable Concrete Anchor is attached must be capable of supporting loads as detailed in Section 4. This anchor may be installed overhead, vertically, or horizontally. If the anchor is installed below the FBH dorsal d-ring, a PFAS designed for extended free fall scenarios must also be used. When properly installed, the anchors may be used as part of a PFAS, restraint or work positioning system.

Application Limits

It is imperative that the RCA5K Removable Concrete Anchor is installed to specifications detailed in this manual – specifically to ensure the correct tools are used for installation, that the hole depth and diameter conform are within requirements, and that the substrate is strong enough to support the intended loads. Additionally, care should be taken when reusing the anchor in a previously drilled hole and/or if the anchor is difficult to remove due to being ‘lodged’ within the hole. Regardless, A COMPETENT PERSON MUST INSPECT PROPER INSTALLATION AND REMOVAL OF THIS REMOVABLE CONCRETE ANCHOR.

Approved Applications

The RCA5K Removable Concrete Anchor may be used for the following applications, as detailed in the figures below. Note that this list is intended to anticipate the most common applications of this anchor and is not exhaustive.

- A. Personal fall arrest** – the anchor is designed to be used as single person anchor point for a personal fall arrest system, including horizontal lifelines. Use for the purpose of suspension is prohibited.
- B. Work positioning** – the RCA5K Removable Concrete Anchor may be used as a component of a work positioning system to support the user at a work position. Work positioning systems typically include an FBH with integrated side D-ring, a body belt, and a positioning lanyard. A back up PFAS is required when the user is exposed to a free fall of 2 ft (1.8 m) or more.
- C. Restraint** – the RCA5K Removable Concrete Anchor may be used as a component of a restraint system to prevent the user from reaching a fall hazard. Restraint systems typically include a full body harness containing a body belt and a lanyard or restraint line.

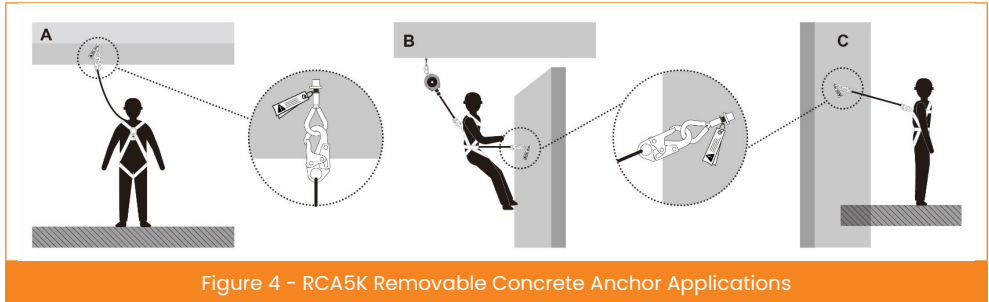

Figure 4 - RCA5K Removable Concrete Anchor Applications

8. Installation and Use

Plan The Personal Fall Arrest System (PFAS)

Before use, users must carefully examine the work area and address all potential hazards. When working at height, falls are a serious hazard. Comprehensive fall hazard management with a PFAS concerns both equipment and training with regard to the below closely related factors (among other things):

- » Anchorage
- » Minimum Required Fall Clearance (MRFC)
- » Swing Fall and Expanded Work Zone
- » Overhead (above the FBH D-ring) Anchorage
- » Non-overhead (below the FBH D-ring) Anchorage
- » Rescue Plan

See the personal fall arrest system manufacturer's instructions for more information.

Pre-Use Instructions

Users must inspect the RCA5K Removable Concrete Anchor thoroughly before each use. A comprehensive pre-use inspection of the RCA5K Removable Concrete Anchor should ensure the label is affixed to the anchor and the anchor is free of any faults including cracks, bends, deformation, corrosion, or twisting. For more details concerning inspection, refer to Section 11. If any of these conditions exist, remove from service. When reusing a previously drilled hole, always inspect the hole for damage or wear.

Anchorage

For requirements concerning appropriate anchor points, refer to Section 4.7. Only use compatible connectors when connecting with an appropriate anchor point to avoid unintentional disengagement. Additionally, ensure all connectors close and lock securely before use.

Minimum Required Fall Clearance (MRFC)

The MRFC defines the minimum distance a user needs between themselves, and the nearest obstruction (or ground) located below the walking/working surface to avoid serious injury or death in case of a fall. To ensure there is sufficient clearance in the fall path, users of this equipment must determine the MRFC for units discussed in this manual. When determining the MRFC, users must consider variables discussed in this manual (i.e.: the height of the anchor point relative to the user's FBH Døring), and those indicated in the user manuals of other relevant connecting devices.

Installation Instructions

1. Drill a .75" diameter hole at least 3.5" deep. The drilled hole must be straight and perpendicular to the surface. Make sure the hole is of uniform diameter and free of peaks and valleys on the inner wall.
2. Blow hole clean using compressed air.
3. If using a previously drilled hole, always inspect it carefully before installing this anchorage connector.
4. When installing the anchor, place your thumb inside the anchor loop and your first two fingers around the trigger. Squeeze fingers and thumb together till the trigger and spring fully compress.
5. Insert unit at least 3" deep into hole and release the trigger. Do not force. Do not insert past the red line.
6. Set the unit with a slight tug on the anchor loop. The stop sleeve must always be partially inserted into the hole.
7. Refer to Table 1 for hole location and concrete thickness requirements.



Do not alter or intentionally misuse this equipment. Attempting to install the anchors in wood, hollow block, steel, or any substrates other than concrete could cause anchor failure and result in serious injury or death. Take action to avoid sharp and/or abrasive surfaces and edges when possible.

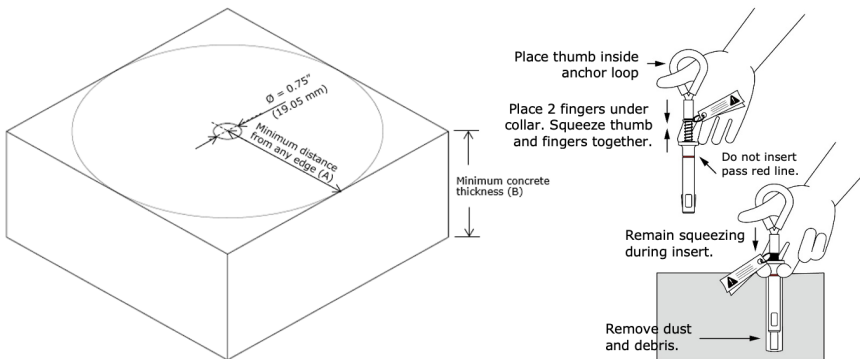

Figure 5 - Hole Drilling Instructions

Table 1 – Hole Drilling Requirement

(A) Minimum Distance from Any Edge/Corner	(B) Concrete Thickness
6"	12"
12"	5"

9. Removal

» **Step 1**

To remove anchor, place a thumb on the Connection Loop while grasping the Collar with two fingers.

» **Step 2**

Push the Connection Loop and Collar together, then pull the unit out of the hole.

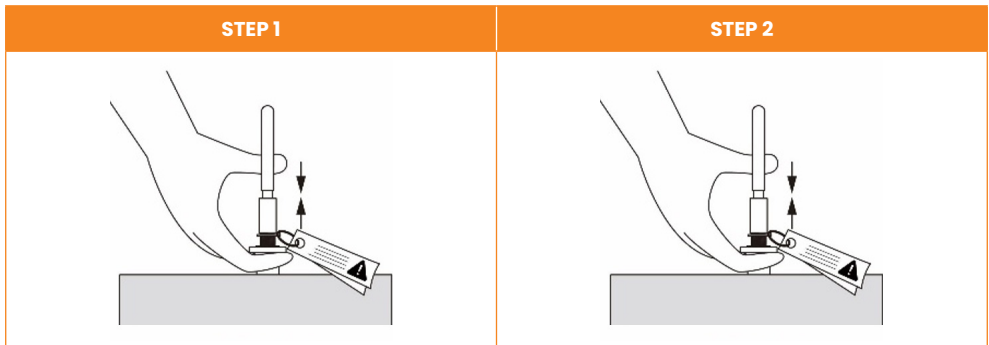

IMPORTANT: If the hole is damaged on anchor removal, mark hole as unusable

10. Reuse and Disposal

Reuse

If the 5CA5K Removable Concrete Anchor has been subjected to forces associated with a fall, it cannot be reused.

Disposal

If the 5CA5K Removable Concrete Anchor was subjected to forces associated with a fall or inspection reveals an unsafe or defective condition (see criteria outlined in Section 11), it should be removed from service and destroyed. Before the 5CA5K Removable Concrete Anchor is disposed, destroy the Anchor in a way to eliminate the possibility of unintentional reuse.

11. Inspection

Frequency

Before each use the RCA5K Removable Concrete Anchor should be visually inspected as per instructions detailed in Sections 11.2 and 11.3.

Annually

A competent person other than the user must formally inspect the 5CASK Removable Concrete Anchor and its connection to its respective structure at least annually. The actual frequency of inspections should consider the conditions of use or exposure. Refer to Table 2 for inspection frequency and Sections 11.2 and 11.3 for inspection steps. Record the inspection results in the inspection and maintenance log in Appendix B.

Table 1 – Inspection Frequency			
Type of Use	Application Examples	Conditions of Use	Inspection Frequency (by a Competent Person)
Infrequent to Light	Rescue and confined space, factory maintenance	Good storage conditions, indoor or infrequent outdoor use, room temperature, clean environments	Annually
Moderate to Heavy	Transportation, Residential Construction, Utilities, Warehouse	Fair storage conditions, indoor and extended outdoor use, all temperatures, clean or dusty environment	Semi-annually to Annually
Severe to Continuous	Commercial Construction, Oil and Gas, Mining, Foundry	Harsh storage conditions, prolonged or continuous outdoor use, all temperatures, dirty environment	Quarterly to Semi-annually

IMPORTANT: Anchors subjected to extreme working conditions (harsh environment, prolonged use, etc.) may require more frequent inspection.

Inspection Steps

The RCA5K Removable Concrete Anchor should be inspected as illustrated below, as per the frequency detailed in Section 11.1:

- » **Step 1**
Check that the RCA5K Removable Concrete Anchor is straight and is operating smoothly.
- » **Step 2**
Ensure the label is attached to the RCA5K Removable Concrete Anchor and is legible (see Appendix A for images of labels).

» **Step 3**

Ensure all components are in good working condition – i.e.: not kinked, frayed, damaged, excessively corroded, or defected in any way.

» **Step 4**

Make sure the wedges operate and move smoothly, and that no metal burrs are present. Also ensure that wedges do not exhibit any deformities.

Defects

Immediately remove the 5CA5K Removable Concrete Anchor from service if inspection reveals a defective condition. Disposal of defective anchors should be conducted as described in Section 10.2.

Product Life

The functional life of the 5CA5K Removable Concrete Anchor is determined by work conditions and maintenance. If the product passes inspection criteria, it may remain in service.

12. Storage, Service, and Maintenance

Maintenance and Cleaning

- » Periodic cleanings will prolong the life of this product. Cleaning frequency should be determined based on inspection and severity of the environment.
- » Clean the device with compressed air and/or a stiff brush using water or a mild soap and water solution.
- » Do not clean the concrete anchor with corrosive chemicals, as these may damage the product.
- » After cleaning, wipe all surfaces with a clean, dry cloth and hang unit to dry or use compressed air.

Storage

- » When not in use, store the device in a clean, dry, and cool environment, out of direct sunlight and free of corrosive or other degrading elements.
- » Position the device in such a way that excess water is allowed to drain out.
- » Avoid exposing devices to chemical or caustic vapors.
- » After a prolonged period of storage, thoroughly inspect the device.

Service

The concrete anchor is not user repairable. If the concrete anchor does not pass pre-use inspection, tag as “UNUSABLE” and either (a) dispose of it, or (b) contact an authorized service center.

13. Appendix A: Labels

LSD LIFE SAFETY DEVICES SECURE YOUR STEPS. EMPOWER YOUR SAFETY.

REUSABLE CONCRETE ANCHOR #RCASK

**Prior to use, read and understand all
Manufacturer's instructions provided with
equipment at time of shipment.**

Material
Stainless Steel, Aluminum

Max Capacity
310 lbs.

MBS
5,000 lbs. (22kN)

Compliance
ANSI Z359.18 Type A

Serial No.:
XXXX-XXXX

Inspect device prior to every connection,
if any deficiencies are found, immediately
remove product from use and contact
LSD Safety.

Warning

DO NOT REMOVE LABEL

All users must read and understand
instructions and labels provided with this
equipment. Failure to do so could result in
serious injury or death. If instructions, label,
or warnings are missing, do not use and
contact the manufacturer.

Made in PRC

LSD LIFE SAFETY DEVICES SECURE YOUR STEPS. EMPOWER YOUR SAFETY.

INSPECTION GRID

User must inspect prior to EACH use.
Competent Person must complete
formal inspection every 6 months.
Competent Person to inspect and
initial.

Date of First Use:

**Product lifetime is 5 years from
Date of First Use, or, if not recorded,
from Date of Manufacture, as long
as equipment passes pre-use and
Competent Person inspections.**

	YR	20__	20__	20__	20__	20__
MO						
J						
F						
M						
A						
M						
J						
J						
A						
S						
O						
N						
D						

If equipment fails inspection
IMMEDIATELY REMOVE FROM SERVICE

DO NOT REMOVE LABELS

SERVICE AND INSPECTION RECORD

SERIAL NUMBER:		
MODEL NUMBER:		
DATE PURCHASED:		DATE OF FIRST USE:

INSPECTION DATE	INSPECTIONS ITEMS NOTED	CORRECTIVE ACTION	MAINTENANCE PERFORMED
Approved by:			
Approved by:			
Approved by:			
Approved by:			
Approved by:			
Approved by:			
Approved by:			
Approved by:			
Approved by:			
Approved by:			

Life Safety Devices
222 Clifford St.
Newark, NJ 07105
1-800-429-0896
www.LSDsafety.com

